

MATELECT SM MODULAR SCANNER SYSTEM

Type SC-1, SM-1 and SM2



INSTRUCTION MANUAL

MATELECT LIMITED

7 Park Place, Newdigate Rd, Harefield, UB9 6EJ, UK

Telephone +44 (0)1895 823 334

Facsimile +44 (0)1895 824 300

Email: info@matelect.com

Web: www.matelect.com

Copyright 2007 Ver 12

SM SCANNER SYSTEM

TYPE SC1, SM1, and SM2

Thank you for your interest in our products, we hope that these will serve your needs and prove reliable tools.

The products have been designed to the highest standard in both electronic and mechanical design, with careful attention to stability, reliability and electrical safety.

The scanner system provides a modular way of monitoring multiple specimens or areas of interest and is designed for use in conjunction with the CGM series of crack growth monitors manufactured by Matelect. For further details on the latter, please see the Matelect CGM-5R instruction manual.

IMPORTANT

Please read these instructions carefully before you use the equipment. For your reference please also read our terms and conditions of sale printed at the rear of this manual.

Please note that there are no user serviceable parts within the scanner system. Never attempt to open an instrument case, unless given express permission to do so by Matelect, as this will void any warranty. Please contact Matelect should you ever experience any difficulties.

MATELECT LIMITED

33 High street, Harefield, Uxbridge, UB9 6BX

Telephone: +44 (0)1895 823 334

Facsimile: +44 (0)1895 824 300

E-mail: info@matelect.com

2. MAINS OPERATION

*This section applies to all mains operated instruments
PLEASE READ BEFORE OPERATION*

The SM system is usually powered via a standard CGM-5/5R unit however, in certain circumstances, a separate power supply (the PSU-1) may be employed as an alternative source. This is an in-line unit that supplies the required DC voltage for the SM system. It has to be plugged into your local EARTHED mains supply.

Before use, please make sure that the PSU-1 supply rating is correct for the location it will be used in. The PSU-1 can only be operated on *either* 110 or 230V supplies (NOT BOTH). The correctly rated unit for your locality will have been supplied on initial system shipment.

The PSU-1 must be connected to the mains supply using the fitted mains lead terminated with the appropriate local mains plug.

The SM instruments are housed in metal cases for strength and electromagnetic screening purposes. To be effective, the enclosures must be connected to mains Earth. This connection is either derived via the CGM unit's AUX. power output OR via the PSU-1. Therefore, if using the PSU-1, PLEASE ENSURE that it is at all times fitted with an Earthed mains connector and that a mains Earth is present at the power socket.

If the PSU-1 is fitted with a fused mains plug, a 3 Ampere fuse should be used. The PSU-1 is equipped with a short circuit cut-out if the internal regulator is overloaded.

Ensure that the SM system and, in particular, the PSU-1 does not come into contact with fluids or corrosive gases and that the equipment is operated within the temperature range of 0-40 Degrees C

3. CONTENTS

1.	Welcome	Page 3
2.	Mains Operation	Page 4
3.	Contents	Page 5
4.	Overview	Page 6
5.	General Description	Page 7
6.	Front Panel Descriptions	Page 10
7.	Rear Panel Descriptions	Page 12
8.	General usage advice	Page 15
9.	Electrical Connections: Further info.	Page 20
10.	Specifications	Page 24
11.	Warranty Information	Page 25

4. OVERVIEW

The SM multiplexing system was developed to permit the extension of the single channel mode of Matelect ACPD crack growth monitors, to multiple channel use. Thus an individual AC instrument can be used to monitor defect activity in multiple specimen configurations or at multiple sites on a single specimen.

The SM system is modular and can be specified (or expanded) to cover a total of 256 (see page 17) specimen channels. Each module is based on an 8 channel switching unit. Two types of unit exist; the SM1 is used for switching the ACPD signals whilst the SM2 is used to switch the AC excitation current. Both modules (and up to 32 of each type) are under the control of a single Scan Controller unit, the SC1.

The Scan Controller can be operated in one of three modes; **MAN**ual, **AUTO**matic or **EXT**ernal. When under **EXT**ernal mode, commands can be sent to the SC1 by a host computer and hence the scanning sequences can be operated under software control. By employing the computer to also log the resultant ACPD data from the crack growth monitor, a complete scan control and logging system can be constructed. To this end, Matelect produce sophisticated software which will run on most PC compatibles of 80xxx based architecture.

This manual covers the hardware aspects of the SM series scanners. Additional manuals are available to cover Matelect scanner software products (CGMpeek16 and CGMscan) and our ACPD crack growth monitor (CGM-5R). For further details, please contact Matelect or your local representative.

Within this manual, text shown in **BOLD CAPITALS** is usually used to indicate lettering that appears on the front/rear panels of the hardware in question.

5. GENERAL DESCRIPTION

The component parts of the multiplexing system consist of the SM1 Voltage Switching module, SM2 Current Switching module and the SC1 Scan Controller. The SM1 and 2 both contain relays to switch the signals and currents to and from the CGM unit under **MAN**ual, **AUTO**matic or **EXT**ernal PC control.

The system should be assembled using the diagram below as a guide. The various equipment leads are all illustrated overleaf together with their respective functions.

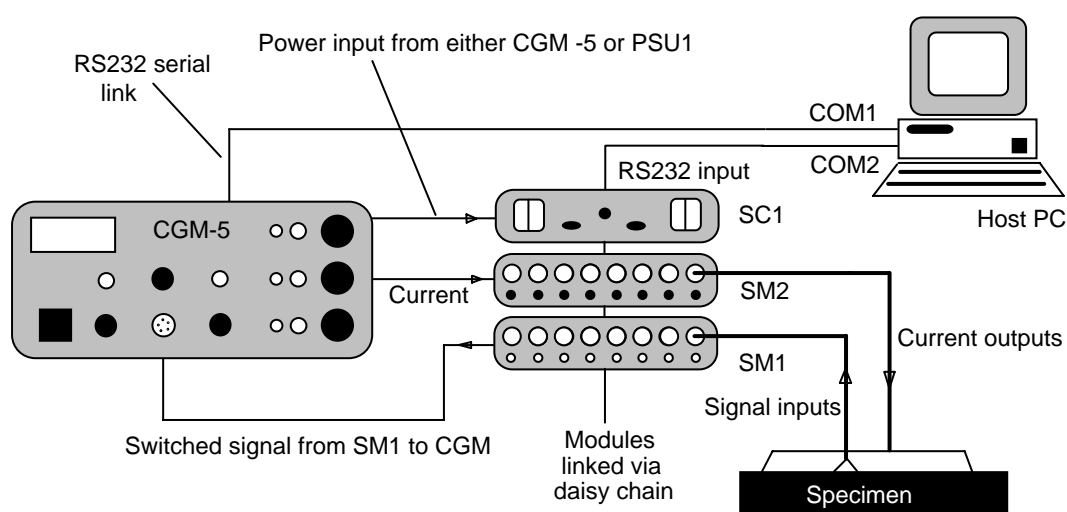

Fig 1. Schematic diagram of the SM ACPD multiplexing system

The system illustrated above constitutes the basic 8 channel set-up. Further SM units (either current or voltage or both) can be added to expand the system (see the subsection on System Expansion on page 17).

The SM system is usually operated in **EXT**ernal mode in conjunction with Matelect scanner software. The software options available are described on page 15. It is also possible for users to write their own coding to operate the scanners and read data from the CGM instrument. Further information on this topic is also given on page 15 and in the CGM-5R instruction manual.

The two other modes of operation, **AUTO** and **MAN**ual are useful for testing out the connections, scanners and signal levels before commencement of the final scanning and logging sequence under **EXT** computer control. Brief details of these modes are given on pages 9 & 14.

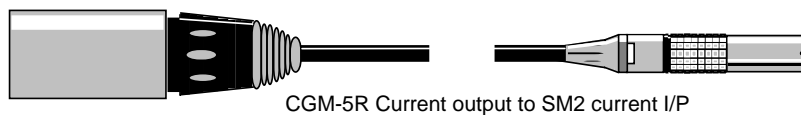
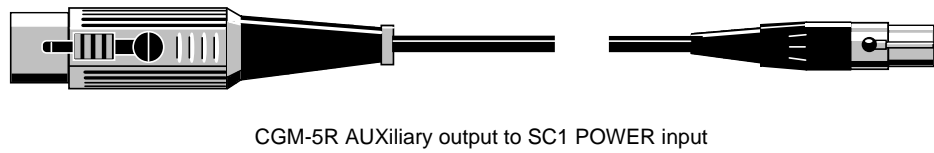
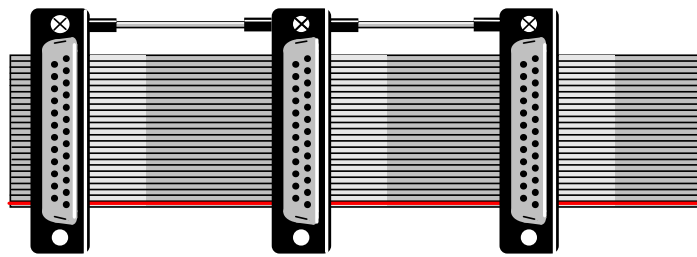
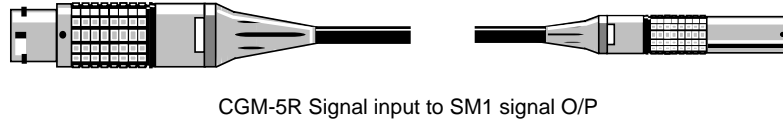

Fig 2. Cables supplied with the SM multiplexing system

Please note that some systems that are pre-supplied with a PC will have the COM cables terminated in the either 25 way or 9 way D connectors (see also page 16).

In addition to the cables illustrated previously, scanner systems that have more than 8 channels of current and/or signal capability are supplied with expander units which handle the distribution of the signal and current to each module of a particular type.

The expanders (see Fig 3 below) allow 3 modules of any one type (i.e. a 24 channel system) to be linked. Supplied systems which extend beyond 24 channels are normally self contained rather than modular in construction in order to reduce costs.

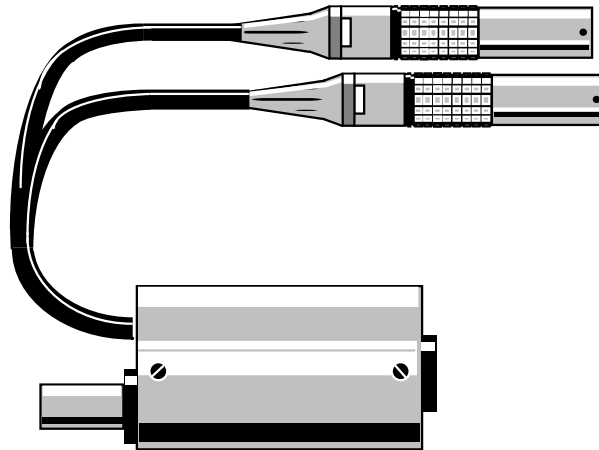

Fig 3. LEMO I/O expanders

Two types of expander are required, one for the Current modules and another for the Signal modules. They differ only in the number of pins used within the LEMO plugs and sockets. Users should therefore ensure that the correct expander is fitted to each of the scanner types.

To install the expanders, users should plug the body of the expander into the chosen module in place of the normal CGM-5R to SM current lead or voltage lead. That lead can *then* be plugged into the LEMO connector protruding from the expander's body.

The two LEMO "flying" sockets emerging from the expander should then be plugged into the remaining module(s) *of the same type as the first* (unused flying sockets can be left dangling and unconnected).

Users should ensure that before insertion of any LEMO plug into a socket they first check that the connectors are compatible and contain the same number of pins, and second, that the connectors are correctly aligned (ridge meets keyway). Red dots and lines are printed on LEMO connectors to aid alignment.

6. FRONT PANEL DESCRIPTIONS

The SM1 and SM2 front panels simply consist of 8 LEMO type input sockets which act to either deliver the AC excitation current to the specimen or to accept the ACPD input signals from the specimen. The current output sockets are three pin types whilst the signal input sockets are two pin. A row of red LEDs (for the SM2) or green LEDs (for the SM1) is positioned under the LEMO connectors. The active channel is indicated by a lit LED.

Only the designated LEMO plugs should be used (see Specifications, page 20) within these input sockets - any other is likely to cause serious damage to these high precision connectors.

Insertion of a plug into a socket is a simple matter of aligning the in-line protrusion on the plug with the corresponding key way within the socket. Once this is correctly done, the plug can be pushed home until it locks in place. To remove the plug, the outer knurled collar should be grasped and pulled perpendicularly away from the front panel. This will simultaneously unlock the plug and effect its withdrawal.

Users should note that very little insertion force is required with the LEMO connectors. If they *have* to be forced, then there is either a miss-alignment or a miss-match of the connectors.

The front panel of the SC1 is shown in Fig 4 below.

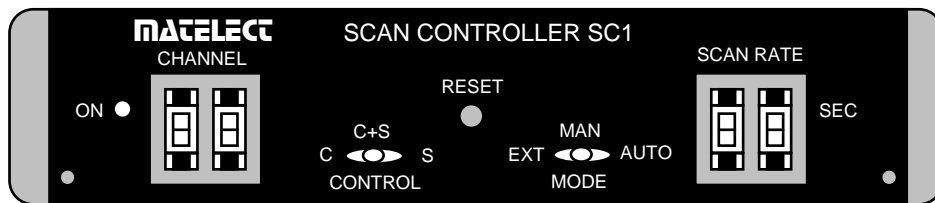

Fig 4. Front panel layout of the SC1 scan controller

1. CHANNEL selector

This comprises a two digit BCD switch which can be adjusted to display channel numbers between 00 and 99 by use of the up/down push buttons located above and below each digit. In **AUTO**matic mode, this control allows the user to select the maximum channel number that the scan sequence will reach.

Matelect SM System Instruction Manual

In **MANual** mode, the SM modules switch to the channel number selected. The **CHANNEL** selector control is over-ridden in **EXTernal** mode.

Please note that the first channel in the scanner system is named channel 0. Thus, an eight channel system comprises channels 0 through to 7 inclusive.

2. CONTROL switch

This three position switch is used to select which type of SM module is to be controlled. In the **S** position only the signal scanner (SM1) is activated by the SC1. In the **C** position, only the current module (SM2) is controlled, whilst in the **C+S** position, both types of module are fed control signals.

If a module type is not activated, that module either remains set at channel 0 or the channel that was previously active remains switched in. The **CONTROL** switch is over-ridden by the host computer when the SC1 is placed in the **EXTernal** mode.

3. RESET switch

This is a momentary action, push button switch that is used to reset the on-board microprocessor within the SC1. Once pressed, it will reset the microprocessor and return the appropriate SM scanner modules to channel 0. The **RESET** function can be used in all three operational modes, however its use in the **EXTernal** mode, whilst scanning is being carried out, can lead to software crashes.

4. MODE selector switch

This three position switch is used to set the operational mode of the SC1. The three modes are characterised as follows;

<i>EXTernal mode</i>	<i>Control of SM system by external host PC. All front panel controls (except RESET) disabled.</i>
<i>MANual mode</i>	<i>Allows manual setting of active channel on each SM module via front panel. CHANNEL control switch operable, SCAN RATE switch inoperable.</i>
<i>AUTOmatic mode</i>	<i>Self activated scan sequences enabled. Sequence rises from channel 0 through to channel number selected by CHANNEL switch. The rate of switching between channels is set by the SCAN RATE control.</i>

5. SCAN RATE switch

This control is used to adjust the time delay between successive switch events. The control comprises a two digit BCD switch which can be adjusted to display times (in seconds between 00 and 99, by use of the up/down push buttons located above and below each digit. This control is only applicable to the **AUTO** mode. In the **EXTernal** mode it is overridden by the host PC and in the **MANual** mode it serves no purpose since the channels are accessed manually via the **CHANNEL** selector control.

7. REAR PANEL DESCRIPTIONS

The rear panel views of all three system modules are shown below. Each module is connected to its immediate neighbour by the ribbon cable daisy chain supplied with the system. The chain distributes channel number information, Earth and power lines. As more SM modules are added to the base SC1, the daisy chain must either be extended or replaced to accommodate the extra modules (see page 17).

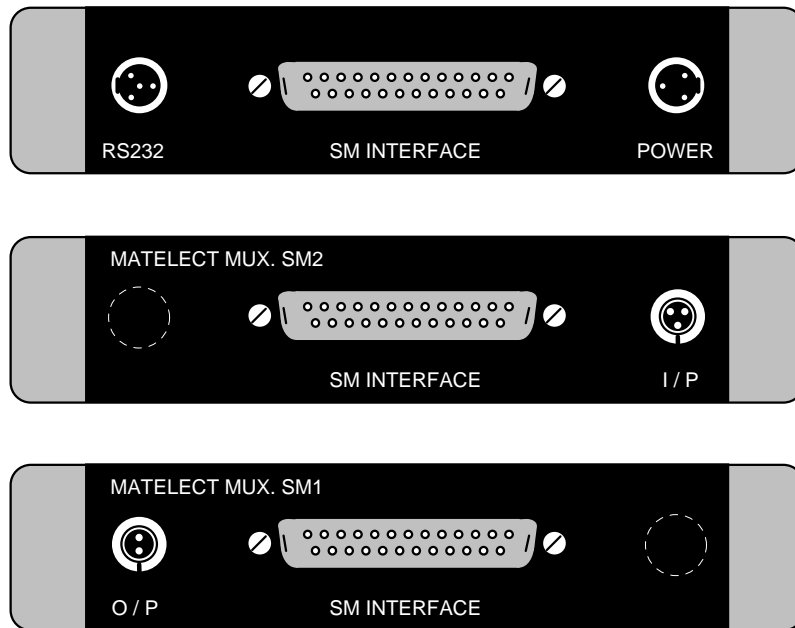

Fig 5. Rear panel views of the SC1 (top), SM2 (middle) at SM1 (bottom) modules

1. SC1 RS232 Connector

This socket style connector is used by the host PC to communicate with the SC1 in **EXT**ernal mode. It is a four *pin* self locking "Switchcraft" type connector and mates with the appropriate Switchcraft plug style connector (*containing 4 sockets*) on the supplied serial lead. This lead is usually terminated in a 25 way D type socket which should be connected to the COM2 serial port of the host PC.

Care should be taken to ensure that the mating plug has its locking tag *correctly aligned* with the keyway in the RS232 socket. If this is the case, then the plug will push home easily.

To remove the plug, finger pressure should be applied to the black unlocking pimple found on the side of the plug so as to release the locking mechanism. The plug can then be removed by pulling it away from the socket.

Do not attempt to plug the POWER lead into this socket or vice versa - the scan controller and/or the socket can be damaged if this is done.

2. SC1/SM2/SM1 INTERFACE connector

This is a panel mounted 25 way D type plug (i.e. with pins) and mates with the corresponding D type socket on the daisy chain connector supplied with the system.

In addition to power and information lines, an earth wire runs along the daisy chain between each connector and thereby connects the cases of the scanner modules together and thence to Earth potential via the metal surround of each **SM INTERFACE** plug. This enhances safety and EM shielding of the SM system. The following table gives the pin functions of the **SM INTERFACE**.

PIN No.	Function
1	Voltage address bit 7 (MSB).
14	Voltage address bit 6
2	Voltage address bit 5
15	Voltage address bit 4
3	Voltage address bit 1
16	Voltage address bit 2
4	Voltage address bit 3
17	Voltage address bit 0 (LSB)
5	Current address bit 1
18	Current address bit 3
6	Current address bit 0 (LSB)
19	Current address bit 2
7	+5 Volt system supply
20	Reserved - do not use
8	+5 Volt system supply
1	Reserved - do not use
9	Current address bit 5
22	Current address bit 6
10	Current address bit 4
23	Current address bit 7 (MSB)
11	Reserved - do not use
24	Voltage mux. enable (active high logic)
12	Current mux. enable (active high logic)
25	0 volt
13	0 volt

Notes:

1. All logic is active high
2. Logic high level between +3.5 and +5 volts
3. Logic low level between 0 and +0.8 volts
4. Connect current and voltage enables (pins 12 & 13) to system +5 volts for normal operation
5. +5 volt supply must deliver at least 120mA

3. SC1 POWER input connector

This is a three pin, self locking "Switchcraft" type that carries +8V, -8V and Common lines from either the external power supply unit (PSU-1) or the AUXillary output socket of a standard CGM-5R.

The precautions regarding this connector are outlined in the earlier section on the RS232 socket.

4. SM2 I/P connector

This is a panel mounted, LEMO type, **three** pin plug that is used as the *input* for the excitation current that is generated by the CGM-5R. This current is switched by the relays within the SM2 and delivered to the specimen(s) via the SM2 front panel connectors.

The connector mates with the corresponding flying socket on the CGM-5R to SM2 lead (see fig 2) supplied with the system. Insertion of the socket into the plug is a simple matter of aligning the in-line protrusion on the plug with the corresponding key way within the socket. Once this is correctly done, the socket can be easily pushed home until it locks in place. To remove the socket, the outer knurled collar should be grasped and pulled perpendicularly away from the front panel. This will simultaneously unlock the socket and effect its withdrawal.

Users should note that very little insertion force is required with the LEMO connectors. If they *have* to be forced, then there is either a miss-alignment or a miss-match of the connectors.

5. SM1 O/P

This is a panel mounted, LEMO type, **two** pin plug that is used as the *output* for the switched ACPD signal that is routed *into* the CGM-5R. The eight signals are switched by the relays within the SM1 and delivered to the CGM via the SM1 to CGM-5R umbilical cable (see fig 2).

The **O/P** connector mates with the corresponding **two pin** flying socket on the umbilical lead supplied with the system. Insertion of the socket into the plug is a simple matter of aligning the in-line protrusion on the plug with the corresponding key way within the socket. Once this is correctly done, the socket can be easily pushed home until it locks in place. To remove the socket, the outer knurled collar should be grasped and pulled perpendicularly away from the front panel. This will simultaneously unlock the socket and effect its withdrawal.

Users should note that very little insertion force is required with the LEMO connectors. If they *have* to be forced, then there is either a miss-alignment or a miss-match of the connectors.

8. GENERAL USAGE ADVICE

SETTING UP THE SYSTEM

The SM system should be configured as shown in Fig 1 using the cable list (Fig 2) as a guide. The scanner modules should first be connected to each other using the daisy chain and then power should be applied using the CGM-5R **AUX**iliary output or the PSU-1 stand alone supply (see below).

The COM1 and COM2 RS232 connections should then be made to the host PC (if used). Finally the current and voltage umbilicals should be used to complete the connections to the CGM. The equipment can then be switched on.

Please note that in certain cases, system software may be supplied that utilises COM2 and COM3 (in place of COM1). This is to enable mouse operation on COM1 (usually within Microsoft Windows) for personal computers that are not equipped with a dedicated mouse port. Details will always accompany the software.

Connections to the specimen(s) are made using leads terminated in the appropriate LEMO plugs (see pages 19 to 22). Matelect can supply stock cable sets (CABL-1 and CABL-2) or manufacture cables to order.

It is important to remember that, when fabricating cables, attention should be paid to minimising the overall length of the cable. In the case of the voltage leads, this helps to reduce EM pick-up and in the case of the current leads, it maximises the available current to the specimen by minimising its resistance.

Users should note that they should never have to force a connector either into or out of its mating socket - undue force implies a miss-alignment of these components and can lead to degradation of the electrical contacts.

POWER SUPPLIES

The scanner system is normally powered from the **AUX.** supply output of a CGM monitor. If the monitor employed is one of the earlier models without this output then Matelect will supply a suitable external power supply unit (the PSU-1) with the SM system.

The **AUX.** supply from the CGM monitor is normally used to power a maximum of 2 voltage and 2 signal scanner modules, plus a scan controller. If it is desirable to extend the system beyond this number of modules, then the separate PSU-1 or an alternative, suitably rated power supply unit, must be used.

If the equipment is already powered by an external PSU then users should check with Matelect, before ordering further scanner modules, that the PSU is capable of handling the power requirements.

USING THE MODES

Once the system has been set up and the specimen connected in, the signal levels present at the specimen can be checked individually using the **MAN**ual mode of the SC1 to step through each channel in turn. Adjustments to the wiring and the CGM controls can then be made in order to optimise the signal levels - before formal testing begins.

The **AUTO**matic mode can be used to check the operation of the scanner system as a whole without the need to use a host computer and software. This mode is therefore of use for locating faults in the system (e.g. with the serial communications).

It *is* possible to operate the SM system without an external computer if none is available. The system then needs to operate in the **AUTO**matic mode, and some means of data logging (e.g. via a chart recorder) has to be employed to record the CGM-5R analogue output.

Unlike a computer program, which can both switch to a channel and record its activity, the above method does not associate the recorded data with a particular channel number and could therefore lead to confused results. It should be avoided if possible.

LOCK-IN TIMES

If the CGM instrument utilised with the scanner system is fitted with an automatic phase adjustment (e.g. CGM-5, CGM-5A, CGM-5D and CGM-5R) then it will be necessary to allow the unit to lock into the specimen signal if correct measurements are to be made.

This is not normally a problem with a single specimen, as lock-in is achieved at the start of the experiment and held throughout its duration. Switching between multiple specimens will, however, cause the CGM instrument to temporarily lose lock.

As a consequence users should adjust the channel delay period so that the CGM achieves lock-in *before* the scanner system moves to the next channel. If the channel delay is too short, then the CGM may not have achieved lock-in by the time the next channel is selected, thus resulting in erroneous readings.

The minimum channel delay should be 2 seconds. However, users may find that longer delays are necessary. Please note that a CGM-5R can take up to 10 seconds to achieve lock-in between signal sources of wildly different phases. As a consequence, long channel delay periods may have to be set. Correct lock-in will have been achieved only after the lock-in LED on the CGM-5R has stopped flashing.

If users experience difficulty in obtaining suitably short lock-in times, then an improvement may be observed if the position of the signal leads is altered. This works because lead movement can affect the pick-up conditions, and pick-up can have an effect on the phase of the measured signal.

In certain cases transposing the connections of the voltage lead at the specimen whilst leaving the current lead as it is (i.e. altering the signal polarity) results in a dramatic improvement in lock-in times. With careful adjustment, it should be possible to bring lock-in times for all channels to within the 2 second suggested limit.

As an alternative, if the system utilises a CGM-5R, then operation of this unit in **RESISTIVE** mode will ensure an instant lock-in, with only a small decrease in signal amplitude. Additionally, the **RESISTIVE** mode reduces the influence of induced pick-up on the test.

When operating in **RESISTIVE** mode users should note that it is perfectly possible to obtain *negative* potential drop readings. These can be registered as positive values by simply reversing the polarity of the corresponding voltage pick up leads.

SOFTWARE

Dedicated software for the logging of ACPD data and the control of the multiplexing system is available from Matelect.

CGMpeek16 is a 16 channel package that performs the logging and scanning functions whilst simultaneously displaying the activity on each channel as a graph of potential drop against time.

The package is DOS based and can be run on IBM compatible PC with processors throughout the 80xxx range. The software can also be run within the Microsoft Windows operating system and appropriate files for Windows operation are included on the installation disk. Although the software is limited to 16 channels on screen, a novel Windows application has been written by Matelect to enable the simultaneous operation of multiple CGMpeek programs, thereby extending the on-screen channel capability in blocks of 16.

For users who do not require on-screen graphics but nevertheless need a robust DOS based package Matelect's CGMscan can be used. Although CGMscan does not have the advanced facilities of CGMpeek (such as alarms, data display, data review and individual channel file names) it can handle up to 99 scanner channels and can be used on the most basic 8086 machines equipped with only limited resources.

For users who wish to write software, Matelect can provide details of protocols etc. In **EXT**ernal mode, the SC1 accepts the following ASCII codes from a host computer;

SX Where S refers to "Signal" (i.e. SM1 modules)
CX Where C refers to "Current" (i.e. SM2 modules)
 Where X refers to the channel number 0 to 255 inc.

Thus sending S4 and C2 in sequence, to the SC1, will instruct it to switch the SM1 to channel 4 and the SM2 to channel 2.

The **RS232** interface on the SC1 is isolated from the Common of the CGM monitor in order to remove the chance of earth loop instability. The **RS232** interface operates at 300 Baud with 8 data bits and no parity bit.

The system is usually supplied with a COM2 cable terminated in a 25 way D connector. The following diagram illustrates the RS232 cable connection for both 25 way and 9 way.

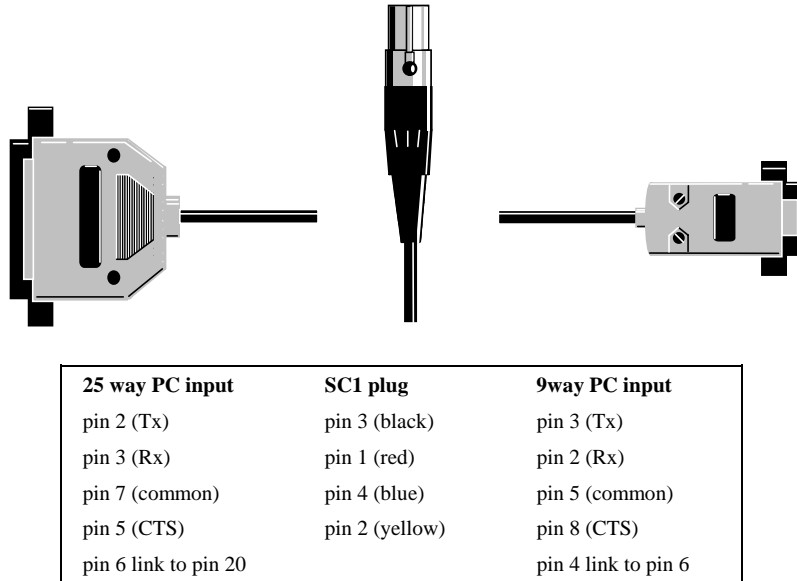

Fig 6. Serial connections between the SC1 and the host computer

MODULE ADDRESSES

Each SM module has an address with which it is accessed by the SC1 scan controller. The addresses are factory set before shipment and determine whether the module is designated as containing Channels 0 to 7, 8 to 15 etc. The modules are labelled on their underside with this designation.

It is important, therefore, when expanding the system by purchasing further modules to specify the required channel designation. Alternatively this can be changed by adjusting the address which is set by a PCB mounted 5 way binary coded DIL switch located within each module. This is done according to the following table;

Channel designation	DIL setting
0-7	00000*
8-15	10000
16-23	01000
etc.	

*(*The left most bit is the least significant)*

Therefore, although **MAN**ual setting of the channel can only extend to channel 99, the **EXT**ernal maximum is 256 channels (11111 corresponds to channels 248- 255).

CGMpeek SOFTWARE TIMING

When employing software control under CGMpeek, users may notice that although the time intervals, as displayed on their computer screen, are regular, the scanner system may occasionally appear to switch channels either slightly faster or slightly slower than the delay set by the user.

This phenomenon occurs because the software is forced to approximate the time interval and the slight error in this method can gradually add until it causes a cumulative error of a second.

This error is corrected elsewhere in the cycle so that on average the correct delay is implemented. Users should be aware of this occurrence, however, since a channel delay that is on the limits of the lock-in time, may be beyond this limit on the few occasions that the cumulative error manifests itself.

Most of these difficulties can be overcome by choosing a generous channel delay.

SYSTEM EXPANSION

The SM multiplexing system can easily be expanded to accommodate further signal and current channels. A theoretical maximum of 256 channels can be handled by the SC1 scan controller (256 signal + 256 current).

However, in practice, the method of connection of the modules to each other limits a *practical* system to 24 channels of each type. Therefore, if there is an intention to operate beyond this practical limit, Matelect will recommend a self contained, rather than a modular, approach. Further information can be obtained from our head office.

Expansion of an 8 channel system to 16 channel will require *one* additional module of each type (assuming both current and signal are to be multiplexed) plus *one* expander unit of each type (see page 7) plus a revised daisy chain **INTERFACE** link containing 5 interface connectors.

Expansion to 24 channels will require *two* SM modules, a revised 7 way daisy chain, but *no* further expander units. It is recommended that a 24 channel system be powered by the stand-alone PSU-1 power supply rather than the CGM-5R's **AUXiliary** output.

With regard to software, the Matelect CGMpeek program can handle up to 16 channels of signal and current in the DOS environment but it will require Microsoft Windows to extend beyond this. CGMscan can be used as an alternative if Windows operation is not appropriate.

Users who are unsure about their expansion requirements should contact Matelect at our head office for further advice and information.

9. ELECTRICAL CONNECTIONS: FURTHER INFORMATION

EARTHING

The SC1 scan controller can be powered by either connecting it to the **AUX.** output of a standard CGM-5R or by using a dedicated power supply unit. In both cases the SC1 is supplied with low voltage power and therefore no danger from mains voltages can result. To prevent the SM system becoming live through contact with external mains sources, the metallic enclosures are held at Earth potential.

The earth line is carried via the power supply connection and distributed to each module through the daisy chain assembly.

SHIELDING & SWITCHING ARRANGEMENTS

Each SM-1 unit contains eight high quality mu-metal shielded double pole on-off reed relays. These are switched by internal logic circuitry under the direct control of the SC-1 scan controller via the daisy chain connector.

For ACPD Voltages, both signal high and signal low lines are switched. The specimen cable shield is connected via the LEMO connectors to the case of the SM-1 (which is held at Earth potential).

The signal output cable from the SM-1, consists of signal high and signal low lines and a shield normally held at Earth potential. To prevent earth loops, the shield is *only* connected to Earth via the shell of the CGM-5 LEMO input socket. The shield is *terminated* just before the SM-1 input socket.

Each SM-2 contains eight high quality, low contact resistance double pole relays with contact ratings of 4A at 240V AC and 3A at 30V DC. These are switched by internal logic circuitry under the direct control of the SC-1 scan controller via the daisy chain connector.

The ACPD current supply is routed through these relays and both current high and current low are switched. The cable shield of the current supply lead from the CGM is NOT connected to the case of the LEMO input connector but is carried on a third pin within the connector. This line is carried right through the SM-2 to the third pin on the 8 current output sockets of the SM-2. Depending on the model year of the CGM-5/5R, this shield is held at either the current supply circuit Common of the CGM or at CGM Earth potential (see Fig 7). The case of the SM-2 is therefore *not* connected to the current shield. The case is, however, connected to Earth via the daisy chain assembly that links the SC1, SM1 and SM2 together.

NB. In early SM-2 models, the case was left fully floating with respect to Earth or Common. Users who have such apparatus and wish to earth the case (e.g. for safety reasons) should do so by removing the top cover of the SM-2, accessing the case terminal within the enclosure and connecting a medium gauge equipment wire to an appropriate external earth (e.g. the Earth terminal on the rear of the CGM-5/5R).

MAKING SPECIMEN CABLES

In general it is recommended that end users purchase Matelect cable sets (CABL-1 for voltage and CABL-2 for current) which can be specified in lengths other than the standard 2 metres. However, for users who wish to fabricate their own specimen cables, a few important points follow.

Cables should be terminated in the correct LEMO type plugs (see the Specifications page).

The signal cables should be of the twisted pair and shield variety (e.g. BICC H8071) with the cores and screen connected as shown in Fig 7.

The Current cables are of thicker gauge (to reduce their impedance and hence maximise available specimen current) and are connected in a similar fashion EXCEPT the Current LEMO plugs & sockets are equipped with a 3rd pin. Two methods of connection exist for the Current cables.

The shield of the Current cables emanating from the 8 output sockets can be connected to the third pin as shown in Fig 7 for screening purposes.

This is the conventional route and one which forms the most obvious solution. However, there is an alternative method of connection which is utilised on 1995 Matelect CABL-2 current cable sets. It has the advantage of better RF screening AND higher current carrying capacity.

The revised method requires the use of cabling that contains a *foil* type shield in intimate contact with a drain wire (e.g. BICC grade H8082). The shield is then used as *one* of the current carrying conductors. Only one of the two conventional cores is then used to form the *second* current conductor. Thus the cable mimics a coaxial arrangement which lowers the radiated field.

The lower resistance offered by the foil shield also serves to maximise the available current through the cable. NO connection is therefore made to the third pin on the LEMO output sockets. This arrangement is illustrated in the Fig 8.

End users who employ either connection technique for the Current leads MUST ensure that the screens and cores of their cables do NOT come into contact with the casing of the LEMO connectors (this can create earth loops and other serious errors). It is therefore advisable NOT to use braided shield cable as it is quite difficult to ensure that all the strands do not come into contact with connector housings.

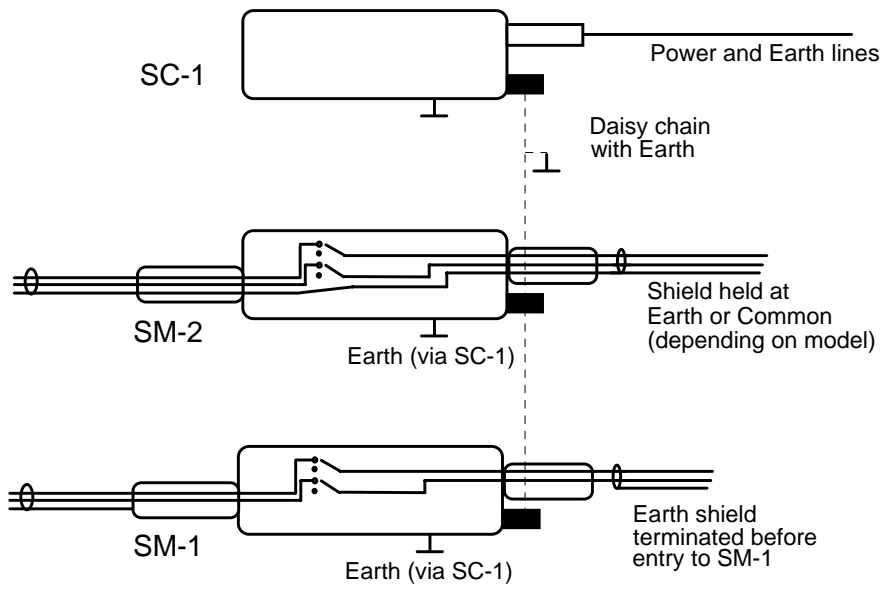

General connection regime for SM1/SM2/SC1

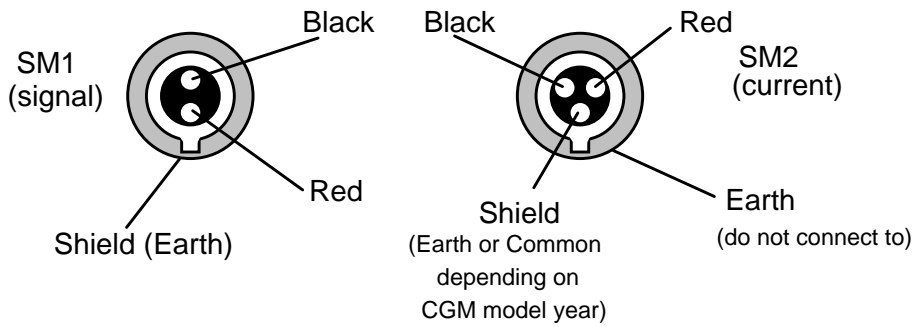

Front panel views of SM1 and SM2 LEMO connectors
 (colours correspond to Matelect CABL-1 and CABL-2 cable sets. Cable shields should be connected as shown to preserve earthing regime)

Fig 7. Wiring schematic of signal and current multiplexing units.

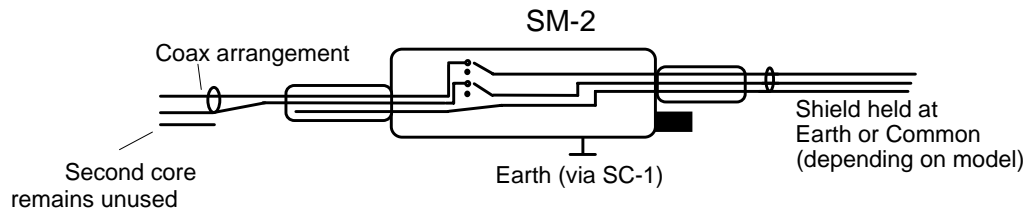

Revised connection regime for SM2

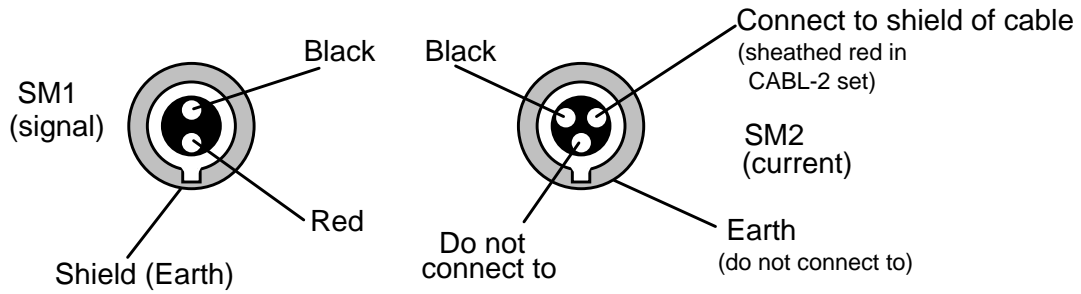

Front panel views of SM1 and SM2 LEMO connectors
 (colours correspond to Matelect CABL-1 and CABL-2 cable sets. Cable shields should be connected as shown to preserve earthing regime)

Fig 8. Improved cable connection regime

End users who are uncertain as to how to fabricate their own cables should contact Matelect for further advice.

10. BRIEF SPECIFICATIONS:

SC1

Type: Microprocessor based (8031) controller unit
Clock speed: 12MHz
Modes: EXTERNAL (PC), MANUAL and AUTOMATIC
Capability: 256 channels in EXTERNAL mode, 99 in MAN & AUTO
Power: +/-8 volts DC @ 300mA
Controls: Channel delay to 99 seconds, manual channel select to chan.99
Comms: Serial RS232, 300 Baud, 8 data, no parity bits
Case: Epoxy coated steel enclosure to IP20

SM1

Type: 8 channel ACPD voltage signal switching module
Addresses: 00000 to 11111
Set via: Internal 5 way DIL switch
Relays: Pickering type double pole changeover dry reed
Rating: 0.5A max at 20V, 0.05A at 200V max
Contacts: Rhodium plate
Power: +/- 8 volts from SC1
Input: 2 pin LEMO type X 8
(mates with FGG0B302CNAD42Z LEMO plug)
Output: 2 pin LEMO to 8 pin CGM-5R input
Case: Epoxy coated steel enclosure to IP20

SM2

Type: 8 channel ACPD current switching module
Addresses: 00000 to 11111
Set via: Internal 5 way DIL switch
Relays: SDS type S2 double pole changeover
Rating: 4A at 240V AC and 3A at 30V DC
Contacts: 5 layer (from CuNi to AuAg)
Power: +/- 8 volts from SC1
Output: 3 pin LEMO type X 8
(mates with FGG0B303CNAD52Z LEMO plug)
Input: 3 pin LEMO to 3 pin CGM-5R output
Case: Epoxy coated steel enclosure to IP20

PSU-1

Type: Stand alone power supply unit
Input: 230V AC 50/60Hz OR 110V AC 50/60Hz
Output: +/- 8 Volts @ 300mA Regulated
Fuse: Internal short circuit protection and 3A fuse (UK plug)

All modules are built to the CE/IEC 1010 standard for electrical safety



11. WARRANTY AND SERVICE INFORMATION

The following text is an extract from our standard conditions of sale. It covers the terms of warranty and liability only. Please refer to the full text, supplied upon delivery of the goods or contact Matelect Limited.

Extract 6. WARRANTY

Items sold by the company are warranted only as stated below.

Subject to the exceptions and upon the conditions specified below, the company agrees to correct, whether by repair or, at its election, by replacement, any defect of materials or workmanship which develops within twelve months after delivery of the instrument to its original purchaser by the company or by any authorised representative provided that investigation and factory inspection by the company discloses that such defect developed under normal and proper use (unless covered by a separate agreement or guarantee written by the company).

The exceptions and conditions mentioned above are the following.

- a). The company makes no warranty concerning components and accessories not manufactured by it. however, in the event of the failure of such components or accessory, the company will give reasonable assistance to the purchaser in obtaining from the respective manufacturer whatever adjustment is reasonable in the light of the manufacturer's own warranty.
- b). The company shall be released from all obligations under its warranty in the event of repairs or modifications being made by persons other than its own or authorised service personnel unless such repairs by others are made with the written consent of the company or unless such repairs are minor or merely the installation of a new Matelect component.
- c). The warranty is only valid providing that the terms of payment in clause 4 are strictly adhered to.
- d). No product may be returned except with the company's permission in writing. After receiving factory authorisation, goods requiring repair or replacement should be sent prepaid to the factory in the original container properly packed accompanied by a Return Goods Authorisation, purchase order or letter stating as completely as possible the defects and the condition under which it occurred.

Extract 8. CONDITIONS PARAMOUNT

The company expressly disclaims any liability of whatsoever nature and in any circumstances whatsoever, to its customers, dealers or agents, except as stated in the forgoing terms and conditions.

Extract 9. These terms and conditions of sale may be amended or altered at any time the company feel it necessary to do so.

REPAIR AND RECALIBRATION:

Matelect Limited can repair and/or recalibrate instruments manufactured by it, after the warranty period has expired. If this service is required then please contact Matelect and we will be pleased to provide a quotation for the work necessary.

